

easycoat/dry

Industrial multi-functional unit for pre-treatment and fixation of fabrics for digital textile printing

Why treat or not to treat the fabrics?

Most of the fabrics, both natural and synthetic, are not ready to receive and retain the colorants properly, especially when the item of clothing or the finished product must then be worn or has to find a practical use in home decoration. Applying a **specific pre-treatment for each individual ink chemistry** is the pre-condition for optimal printing performance, ensuring optimum fastness and brighter colours. The post-treatment of a fabric may also include the further application of post-printing functional fluids, such as anti-mold and sealing treatments.

Why easyCOAT/DRY?

easyCOAT/DRY is the multifunctional platform that meets the needs of industrial pre and post-processing of digital textile professionals. Cibitex has worked closely with textile industries to design easyCOAT/DRY. The system combines the compactness required by inkjet printers with the effectiveness of an industrial production system based on traditional impregnation and drying with stenter. In just few meters, the machine contains the most sophisticated feeding and tension control systems.

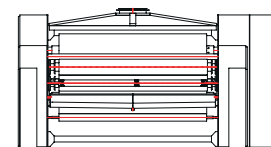

A easyCOAT/DRY 2000

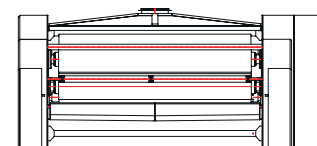

B easyCOAT/DRY 2600

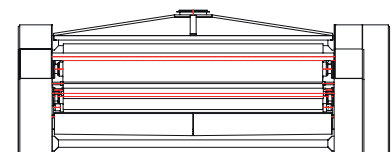

C easyCOAT/DRY 3500

A new way to finish fabrics easyline



1
easycoat

is a professional unit for **pre-treatment** of digitally printed fabrics



2
easysteam

is a compact unit designed for small batches of printed fabrics that require **steam fixation**



3
easywind

is a powerful motorized high precision **winding and coupling** system



4
easywash

is an innovative **professional washing system** for small and medium volumes of printed fabrics



5
easydry

is a compact unit for **drying** digitally printed fabrics



Raw fabrics



— Acid/Reactive
— Pigment

Pre-treatment fluid
for pigment, acid,
reactive, other...

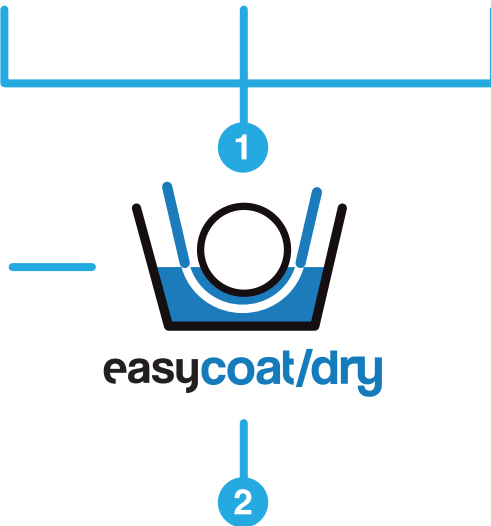

Finished fabrics



Automation & optimization of process

Full integration

easyCOAT DRY is designed as a stand-alone unit to be positioned in the print production department, serving one or more mid-range inkjet printers.

The experience of Cibitex with industrial installations of in-line finishing modules, however, allows the positioning of the machine in-line with a printing equipment, with the full synchronization of linear production speed.



Workflow controlled on a tablet with easyPRESET

*Cibitex easyLINE modules set themselves the goal of **introducing into finishing the same user-friendly production modes of digital textile printing.***

easyCOAT/DRY is controllable by the operator (also remotely) via a simple and intuitive tablet, equipped with an intuitive user interface.

Thanks to the easyPRESET you can then customize, save, retrieve and share with other users the most common and repetitive working parameters, in order to minimize the time of start-up.

1. DIRECT SUPPLY OF FLUIDS FROM TANK

Like industrial inkjet printers, easyCOAT/DRY introduces a **simple and clean production flow**. For this reason the machine is equipped with pumping system connected directly from the tank, with automatic feeding of the soaking basin. At the end of the process the remaining fluid in the basin can be pumped back into the tank, in order to reduce waste to virtually zero, as well as speed up the replacement of the fluid for the next processing.

2. FABRIC UNWINDING UNIT

easyCOAT/DRY is provided with **motorized beam for managing fabrics reels** with diameter up to 300 mm (increasable with Jumbo option) equipped with an optical recognition system of diameter connected to machine's software, which optimizes the rotation speed according to the required fabric tension.

3. FABRIC TENSION OPTIMIZED WITH LOAD CELLS

In order to ensure the compactness of the machine and the maximum response speed of the system to variations of fabric tension, **easyCOAT/DRY has been equipped with a load cell system to replace the traditional dancers**. The machine can thus detect the pull in every single phase of the process, by automatically adjusting the motor speed and providing an optimal tension to guarantee an excellent stability of the fabric.

4. SOAKING AND SQUEEZING

Fabric impregnation remains the most popular method to pre-treat the fabric in the textile industry because it ensures that every part of the fiber receives an adequate amount of pre-treatment, favoring the adhesion of the colorant. easyCOAT/DRY then makes a homogeneous and adjustable squeezing according to the parameters of each single operation, allowing to deposit on the fabric only the amount of fluid required and thus obtaining the maximum quality and colour uniformity in the printing phase.

5. PRE-DRYING UNIT

easyCOAT/DRY is provided with a pre-drying system which finds its principal use in the pre-treatment processes.

Compared to technologies based on IR lamps, this exclusive system allows to remove from the fabric the water and the fluid in excess before the final drying, ensuring greater effectiveness of the treatment, increasing the productivity of the system and preserving the integrity of the fabric and the printed image.

6. HIGHLY-EFFICIENT DRYING AND FIXATION UNIT

Getting **the complete drying and the best performance of pre-treatment without stressing the fabric or affect productivity**: this was the challenge posed by textile printers to the Cibitex engineers. For this reason, the drying and fixation unit, the heart of easyCOAT/DRY, is based on a highly-efficient system of teflon-coated cylinders, allowing to operate at high linear speed with temperatures up to 200° C.

7. WINDING UNIT WITH AUTOMATIC ALIGNMENT

The sophisticated rewinding system of easyCOAT/DRY is equipped with an **automatic centering system with an optical recognition system, which realigns transversely in real-time the motorized carriage** on which the rewinder is installed. On top of this unit is added a widener roller for knitted fabrics that allows the personalized management of the roll winding tension, which help to optimize the reel of fabric for the next processing. The output unit is equipped with a wooden control table and a cross-cutting system mounted on a guide (optional).

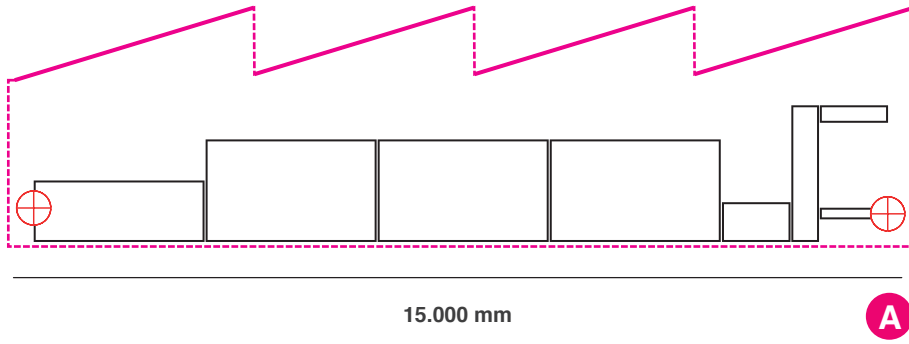

A Conventional pre-treatment plant (example)

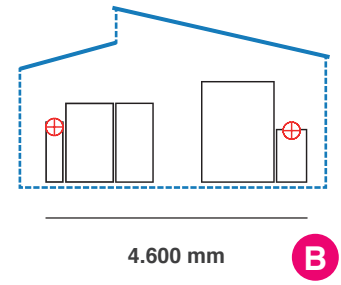

B easyCOAT-DRY system

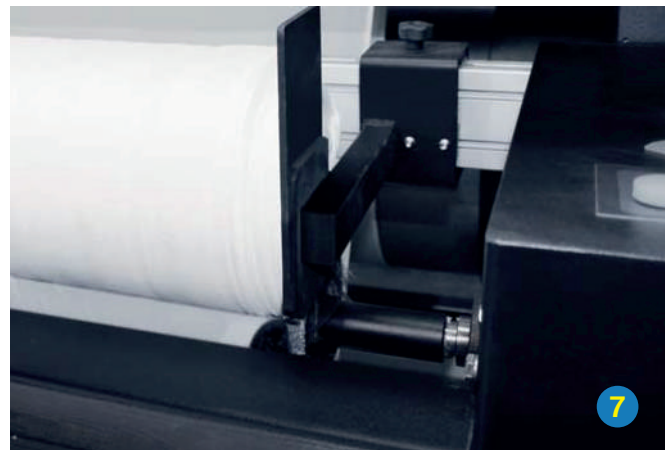
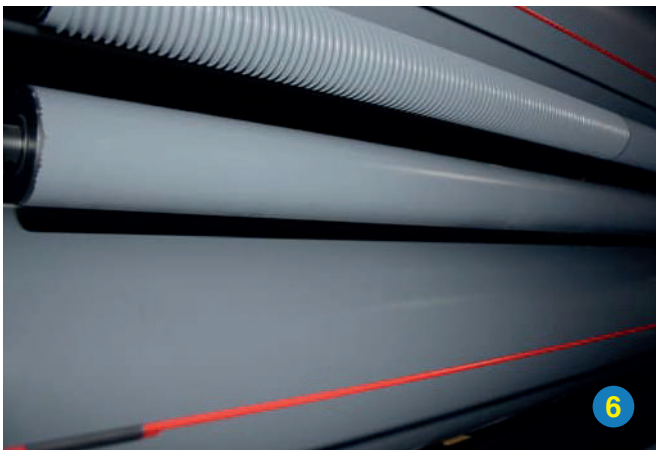
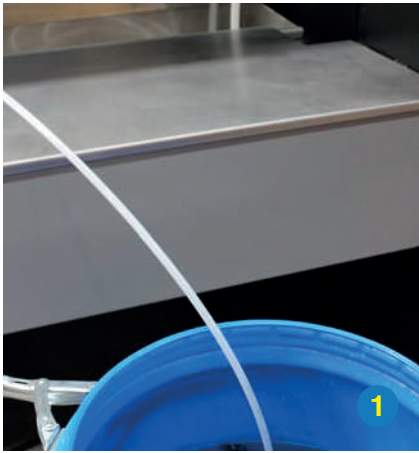

- footprint = + space for your business

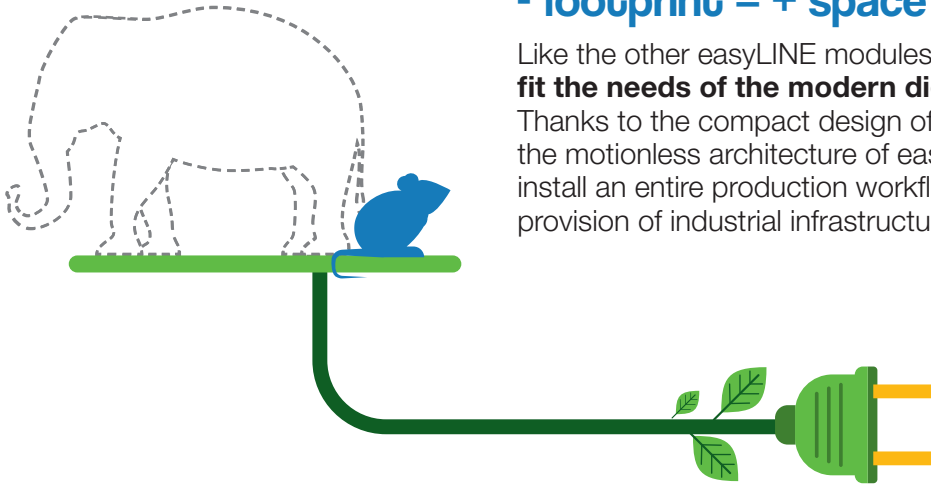

Like the other easyLINE modules, **easyCOAT/DRY is designed to fit the needs of the modern digital textile printing companies.** Thanks to the compact design of easyCOAT/DRY, combined with the motionless architecture of easySTEAM and easyWASH, you can install an entire production workflow in small spaces and without the provision of industrial infrastructure.

Industrial performance with less electricity and reduced consumption

All easyLINE modules are **designed to ensure maximum energy and thermal efficiency, combined with real modularity of consumption,** in order to effectively manage the small and medium-sized productions, typical of digital textile printing.

The time and energy required for the pre-heating of easyCOAT/DRY are reduced to minimum. And the average absorption rate is comparable to that of a highly-efficient heat calender.

More quality, higher fastness

The application of a chemical pre-treatment to raw fabric is recommended by many ink manufacturers to improve the brilliance and color intensity, optimize the definition and the printed image fastness to physical and chemical stress. **easyCOAT/DRY is the unique response to the needs of operators in all segments of the digital textile market,** using both reactive and acid inkjet ink chemistries, as well as the new jettable textile pigments.



A Colour brightness without pre-treatment



B Colour brightness with pre-treatment and fixation

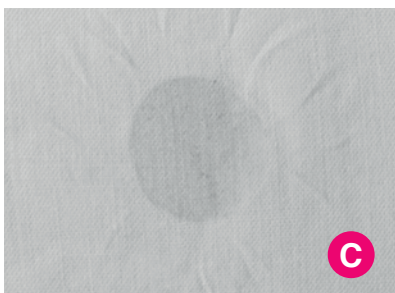

C Fastness without pre-treatment



D Fastness with pre-treatment



Fastness evaluation scale



Zolotoy Gus,
Is an innovative Russian digital textile printing company

"We chose to apply in Russia the best practices of the Italian and worldwide textile production, however, making them compatible with our company size. Hence the choice of an innovative and high quality technology as Cibitex' easyLINE"

- Elena Sukhareva -
Co-founder at Zolotoy Gus

Care for the environment is made of **practical actions**

Cibitex places utmost importance and its commitment to provide the textile industry with sustainable technologies and to adopt good behavior towards the environment and our community.

The energy we use is produced in large part by our photovoltaic system and we adopt the best manufacturing practices to reduce CO2 emissions, water consumption and the production of waste.

We are green

Green philosophy & citizenship

We spend all our efforts to be a sustainable company and provide the textile industry with sustainable technologies.

We are based in the heart of the Olona River Valley, in the great Ticino Park area, a Unesco Man & Biosphere Reserve.

We take care of our local community and wildlife, reducing the noise and the impact of our manufacturing at the lowest level possible.

- We adopt manufacturing machinery, techniques and behaviours that help **reducing CO₂ emissions and water consumption**.
- We **reduce and recycle** all the waste produced by our manufacturing plant according to the strictest rules.
- We manufacture highly efficient technologies that **reduce power consumption** and allow our customers to respect the environment and save money.



A continuous commitment to be virtuous

Cibitex believes in social responsibility as a core value.

For this reason we're constantly engaged in the adoption of internationally recognized best practices in the conduct of our business and customer, suppliers, partners and stakeholders relationship management.

Cibitex is ranked two stars by the Italian Antitrust Authority in the program called 'Legality Rating'.



INFO@S3RTEC.COM • WWW.S3RTEC.COM • TEL: +34 665 549 027

S3RTEC PRINTER & INKS S.L. | CIF: B01890789 | Calle de la Repuntadora, 6 | 08302 Mataró (Spain)